

33 WADE ROAD
LATHAM, NY 12110
(518) 786-1111

25012 / Feb. 2003
60Hz Operation Guide

OWNERS MANUAL



LUXURY SPA LINE



60 Hz
Guide

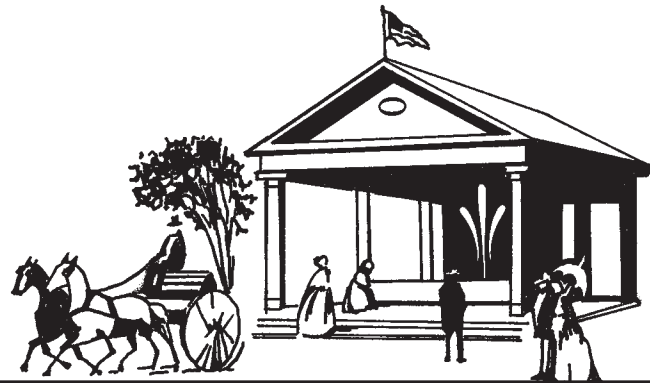

CONTENTS

1.	Safety Instructions	p. 4-5
2.	Installation Instructions	p. 6
3.	Luxury Line Spas	
	3A. Electrical Requirements	p. 6
	3B. Start-Up Procedures	p. 7
	3C. Initial Start-Up	p. 7
	3D. Digital Top Side Features	p. 8
4.	Spa Operation & Temperature Setting	p. 9
5.	Hydrotherapy Jet System	p. 10
6.	Spa Filter Cartridge Installation	p. 10
7.	Spa Care and Maintenance	p. 11-13
8.	Winterizing Your Spa	p. 13
9.	Water Quality Maintenance	p. 13-14
10.	Trouble Shooting	p. 15
11.	Wiring Diagram	back cover

Spa must always be covered when not in use in both indoor and outdoor installations. (Read Below)

IMPORTANT: Whenever the spa is not in use it is essential that the thermal cover be kept in place. When filled this insures effective temperature maintenance and economical operation as well as preventing the spa from pumping out water during power filtration cycle. When empty, this prevents potential damage to the spas surface finish which can result from excessive heat by the sun. These types of damage are specifically excluded from warranty protection . It is also recommended that the thermal cover tie-downs always be used to discourage access to the spa by unsupervised children and minimize heat loss.



Safety Alert Symbol

This is a safety alert symbol. It is used in this manual and on the safety signs and labels to alert you to potential hazards. When you see this symbol, read and obey the message that follows it. Failure to obey safety messages could result in serious personal injury or death.

MODEL: _____

SERIAL NUMBER: _____

DATE INSTALLED: _____

DEALER: _____

ADDRESS: _____

TELEPHONE: _____

NOTE: THE SERIAL NUMBER/IDENTIFICATION LABEL IS LOCATED WITHIN THE EQUIPMENT COMPARTMENT AND SKIMMER HOUSING.

Model	Average Fill Gallons	Weight Filled lbs.	Weight Empty lbs.
#5000 - Polo	150	1585	500
#6000 - Adelphi	240	2385	550
#4000 - Putnam	340	3250	475
#2000 - Excelsior	325	3142	700
#3000 - Clarendon	350	3336	550
#1000 - Canfield	375	3640	700
#2000 - Olympia	375	3630	700
#8000 - Pavilion	525	4989	1000
#9000 - Victoria	525	5084	1000

Thank you for your recent Saratoga Spa purchase.

This owners manual has been designed to acquaint you with your Saratoga Spa's operation and general maintenance.

Keep this manual available for future reference.

If you have any questions regarding your Saratoga Spa, contact your local dealer.

Thank you.

1. IMPORTANT - SAFETY INSTRUCTIONS:

WHEN INSTALLING AND USING THIS ELECTRICAL EQUIPMENT, BASIC SAFETY PRECAUTIONS SHOULD ALWAYS BE FOLLOWED, INCLUDING THE FOLLOWING:

READ AND FOLLOW ALL INSTRUCTIONS.

WARNING - To reduce the risk of injury, do not permit children to use this product unless they are closely supervised at all times.

A wire connector is provided on this unit to connect a minimum No. 8 AWG (8.4 mm²) solid copper conductor between this unit and any metal equipment, metal enclosures of electrical equipment, metal water pipe, or conduit within 5 feet (1.5 m) of the unit.

DANGER - Risk of Accidental Drowning. Extreme caution must be exercised to prevent unauthorized access by children. To avoid accidents, ensure that children cannot use this spa unless they are supervised at all times.

DANGER - Risk of Injury. The suction fittings in this spa are sized to match the specific water flow created by the pump. Should the need arise to replace the suction fittings or the pump, be sure that the flow rates are compatible.

Never operate the spa if the suction fittings are broken or missing. Never replace a suction fitting with one rated less than the flow rate marked on the original suction fitting.

DANGER - Risk of Electric Shock. Install at least 5 feet (1.5 m) from all metal surfaces. As an alternative, a spa may be installed within 5 feet of metal surfaces if each metal surface is permanently connected by a minimum No. 8 AWG (8.4 mm²) solid copper conductor to the wire connector on the terminal box that is provided for this purpose.

DANGER - Risk of Electric Shock. Do not permit any electric appliance, such as a light, telephone, radio, or television, within 5 feet (1.5 m) of a spa. These units DO NOT have an integral ground fault circuit interrupter. The installation of a ground fault circuit interrupter MUST be done by a qualified Electrician and must meet all local and national codes.

The electrical supply for this product must include a suitable rated switch or circuit breaker to open all ungrounded supply conductors to comply with section 422-20 of the National Electrical Code ANSI/NEPA 70-1987. The disconnecting means must be readily accessible to the tub occupant but installed at least 5 feet (1.5m) from tub water.

WARNING - To reduce the risk of injury:

The water in a spa should never exceed 104°F. Water temperatures between 100°F and 104°F are considered safe for a healthy adult. Lower water temperatures are recommended for young children and when spa use exceeds 10 minutes.

Since excessive water temperatures have a high potential for causing fetal damage during the early months of pregnancy, pregnant or possibly pregnant women must first consult a physician before use and never exceed water temperature of 98°F.

Before entering a spa, the user should measure the water temperature with an accurate thermometer since the tolerance of water temperature-regulating devices varies.

The use of alcohol, drugs, or medication before or during spa use may lead to unconsciousness with the possibility of drowning.

WARNING - The use of alcohol, drugs, or medication can greatly increase the risk of fatal hyperthermia.

The causes, symptoms, and effects of hyperthermia may be described as follows: Hyperthermia occurs when the internal temperature of the body reaches a level several degrees above the normal body temperature of 98.6°F. The symptoms of Hyperthermia include an increase in the internal temperature of the body, dizziness, lethargy, drowsiness, and fainting. The effects of hyperthermia include:
1. Failure to perceive heat.
2. Failure to recognize the need to exit the spa or hot tub.
3. Unawareness of impending hazard.
4. Fetal damage in pregnant women.
5. Physical inability to exit the spa or hot tub.
6. Unconsciousness resulting in drowning.

Persons suffering from obesity or with a medical history of heart disease, low or high blood pressure, circulatory system problems, or diabetes should consult a physician before using a spa.

Persons using medication should consult a physician before using a spa since some medication may induce drowsiness while other medication may affect heart rate, blood pressure and circulation.

SAVE THESE INSTRUCTIONS.



At least two additional lugs marked "BONDING LUGS" are provided on the external surface of one of the bonded component's metal enclosure. To reduce the risk of electric shock, connect the local common bonding grid in the area of the hot tub or spa to these terminals with an insulated or bare copper conductor not smaller than No. 6 AWG.

All field-installed metal components such as rail, ladders, drains, or other similar hardware within 3 m of the spa or hot tub shall be bonded to the equipment grounding bus with copper conductors not smaller than No. 6 AWG.

WARNING: Do not use drugs or alcohol before or during the use of a spa or hot tub, to avoid unconsciousness and possible drowning.

WARNING: Pregnant or possibly pregnant women should consult a physician before using a spa or hot tub.

WARNING: Water temperature in excess of 38°C may be injurious to your health.

WARNING: Before entering the spa or hot tub, measure the water temperature with an accurate thermometer.

WARNING: Do not use a spa or hot tub immediately following strenuous exercise.

WARNING: Prolonged immersion in a spa or hot tub may be injurious to your health.

WARNING: Do not permit electric appliances (such as a light, telephone, radio, or television) within 1.5 m of this spa or hot tub.

WARNING: Maintain water chemistry in accordance with manufacturer's instruction.

WARNING: Children should not use spas or hot tubs without adult supervision.

WARNING: Do not use spas or hot tubs unless all suction guards are installed to prevent body and hair entrapment.

WARNING: People using medications and/or having an adverse medical history, should consult a physician before using a spa or hot tub.

WARNING: People with infectious diseases should not use a spa or hot tub.

WARNING: To avoid injury, exercise care when entering or exiting the spa or hot tub.

2. INSTALLATION INSTRUCTIONS:

Your Saratoga Spa is totally self-contained and portable. You can locate it just about anywhere you wish. Preferable places are a patio, deck, or indoors. Regardless of your choice, the spa should always be placed on a structurally strong level surface.

When selecting a site for your spa, be sure to allow for drainage away from the electrical compartment of your spa. Also, allow for access to the equipment compartment.

Do not block air vents to your spa. The air vents allow for circulation of air throughout the equipment compartments. These vents are found on the face of the equipment compartment panel, the floor of the equipment compartment, and under the corners of the spa at the equipment compartment end.

This spa is manufactured to be a portable unit. **Any permanent installation of this product is done at the risk of the owner. Permanent installation of this unit violates warranty coverage.**

3A. ELECTRICAL REQUIREMENTS:

Saratoga Spas must be wired in accordance with all applicable local electrical codes.

All electrical work should be done by an experienced, licensed electrician familiar with spa installations.

NOTE: As of January 1, 1996, The National Electrical Code (NEC) requires a GFCI (Ground Fault Circuit Interrupter) on all spa installations.

The MSPA Series Control is available in a 240 Volt - 4KW heater with 50 AMP service.

240 VOLT MODELS

These spas must be connected to a "Dedicated" 240 Volt 50 AMP grounded circuit. The term "dedicated" means the electrical circuit is not being used for any other electrical items (lights, appliances, etc.) If the spa is connected to a non-dedicated circuit, overloading will occur and nuisance tripping of the GFCI breaker switch at the house breaker panel will occur.

A ground lug connector is provided on the exterior surface of the control box inside the equipment compartment. This is to permit the connection of a bonding wire between this point and any metal equipment, enclosures, pipe or conduit within five feet of the spa. This bonding wire must be at least #8 AWG solid copper wire.



CAUTION: Use only approved pressure-type wire splicing lugs or connectors suitable for the size and type of wiring used!

1. Heater
2. Circuitry Housing
3. Conduit for power input on Backside
4. Mounting brackets
5. Pressure Switch

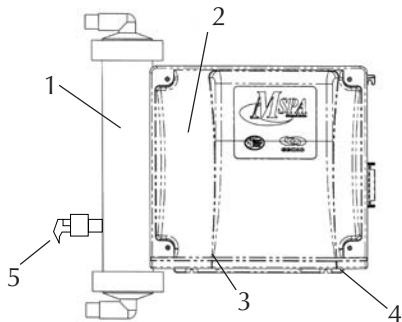

240 VOLT WIRING INSTRUCTIONS:

1. Open the Equipment Module's wiring access panel to allow access to the input power wiring.
2. Connect the input power wiring as shown below. 240 Volt installations require a 60Hz, single phase, three wire electrical service. Plus ground (Line 1, Line 2, Neutral, and Ground), and must be connected using a minimum supply conductor ampacity of 50 AMPS and a minimum circuit breaker size of 50 AMPS.

Note: Use copper wire only (3 wire w/ground. 8 gauge under 50', 6 gauge over 50').

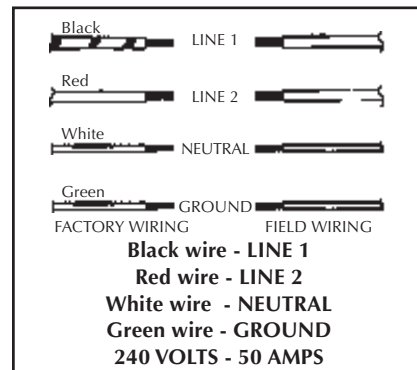

3B. START-UP PROCEDURES:

IMPORTANT: BEFORE FILLING WITH WATER, DO THE FOLLOWING CHECKS:

- A. HAND TIGHTEN UNIONS AT PUMPS AND HEATER
- B. TIGHTEN DRAIN VALVE
- C. CHECK CLAMPS
- D. OPEN BLEEDER VALVES IN FILTER COMPARTMENT

NOTE: Above items may become loose in transit.

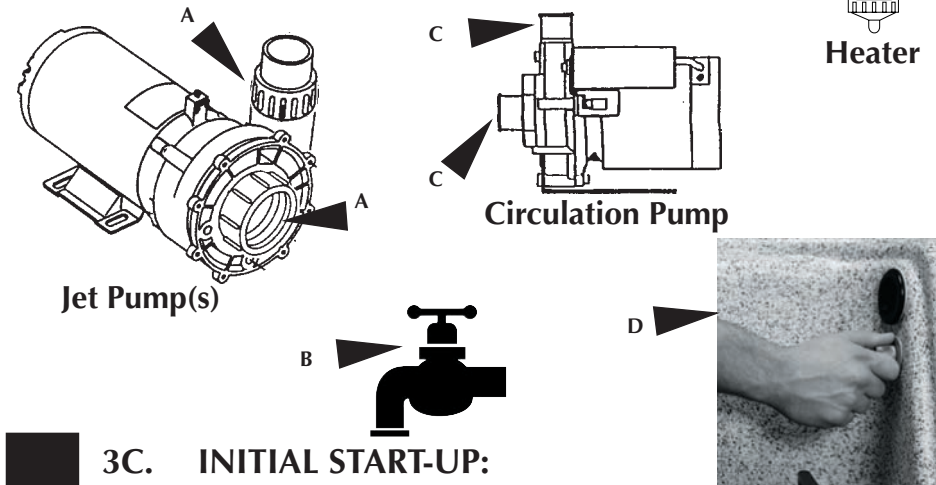

3C. INITIAL START-UP:

1. Fill the spa with water by removing the Whisper Clean cartridge (the Whisper Clean cartridge is the cartridge with the coarse thread (ACME) style. Run water until it reaches a minimum level of 2" above the top of the filter.

Note: When filling your spa, the air bleeder valve must be open in your filter cartridge area. Leave valve open until all pumps are running normally, then tighten bleeder valve snug.

Note: This is the minimum level allowed to run Whisper Clean Circulation System. All models will need to be filled 2" above highest jets.

When using mineral cartridge system, please refer to your dealer for specific instructions on installation.

CAUTION: The Equipment Module must never be operated without water in the spa; serious damage to the heater and/or pump may result.

2. Check all plumbing (clamps, union and drain valve) connections for leaks.
3. Bring power to spa control system. The MSPA control will begin heating the spa to the set

temperature (Preprogrammed for 95°F.) The minimum temperature is 59°F and the maximum temperature is 104°F. The spa has a 24 hour circulation pump and ozone generator to constantly filter and ozonate the water. One minute after power-up, the blower, Pump 2 and Pump 3 will run for 60 seconds and Pump 1 will run on low speed for 15 minutes. The airline purge and power filtration cycle is repeated every 24 hours at this exact time.

NOTE: If water is not coming out of the bottom drain, the system is air bound - Refer to the Trouble Shooting Section of this manual for further instruction. (page 14)

NOTE: It may be necessary to press and release the ground fault circuit interrupter (GFCI) RESET button.

NOTE: If power is interrupted, the filtration cycle will be reset and the temperature setting will return to the previously set temperature..

5. Water must be balanced and shocked upon start up. See your dealer or pages 12 & 13 of this manual for details. This procedure must be repeated each time the spa is drained and refilled.

3D. DIGITAL TOP-SIDE FEATURES:

DIGITAL SPA CONTROL FEATURES:

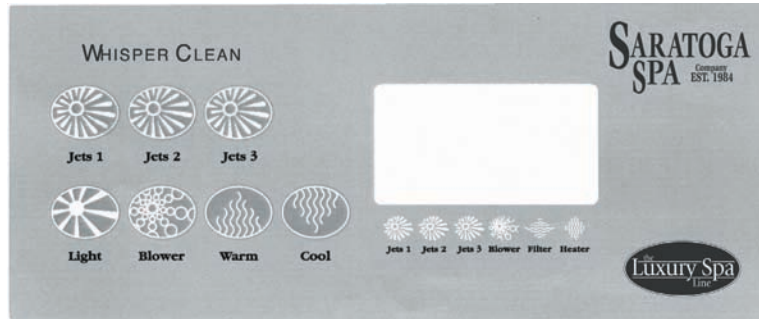

- 1. DISPLAY PANEL**
The display will indicate operation of the hydro jet pump(s), air blower, spa light, water temperature, and display the topside diagnostics.
- 2. JETS 1 BUTTON**
Activates the hydro jet pump for maximum hydrotherapy jet action. Touch button once for low speed, the jet icon will flash. Touch button again for high speed (the jet icon will be on solid) and again to turn off.
- 3. BLOWER BUTTON**
Activates the 3 stage blower. Touch the button once for high, again for medium, again for low and then off. While running on medium or low speed, the blower icon will flash. When operating bubbles of air will come from air jets or versa-flo jets in the spa.
- 4. MOOD LIGHT BUTTON DIMMABLE**
Activates the mood light. (ON,OFF)
- 5. WARM AND COOL BUTTONS**
Used to set the desired water temperature, up or down.
- 6. JETS 2 BUTTON**
This button will activate the secondary hydro jet pump for additional hydrotherapy jet action. Touch button once for low speed, the jet icon will flash. Touch button again for high speed and again to turn off.
- 7. JET3 BUTTON (Pavilion and Victoria only)**
This button will activate the 3rd hydro jet pump. Touch button once for high speed, again for off.
- 8. SATELLITE TOPSIDE (Victoria only)**
This keypad has 4 keys which have exactly the same functionality as the *Pump1*, *Pump2*, *Pump3* and *Blower* keys on the main keypad.
- 9. PANEL LOCK**
To lock/unlock the panel, simply press on the blower key for at least 5 seconds. At that point, "Loc P" will display. If the key is released at this time, the keypad will partially lock (locks only the programming functions). However, if the blower key is kept pressed for another 5 seconds, "Lock F" will appear and the keypad will be fully locked (locking all keypad functions).
- 10. INDICATOR**
Signals operation of pump, blower or heater. Shows temperature, temperature setting, all self diagnostic functions and locking symbols.

LCD INVERT

The invert feature will flip the text on the LCD so it can be easily read from both inside and outside of the spa. To invert, hold the Light button down for 5 seconds. To return the text to its original position, repeat this process.

Self Diagnostics

The Saratoga Digital Spa Control features a series of self diagnostic symbols:
FLASHING TEMPERATURE, FLASHING ●●●
FLASHING Δ AT FILTERING ICON. For a complete description of these features see page 14 of this manual.

4. SPA OPERATION & TEMPERATURE SETTING:

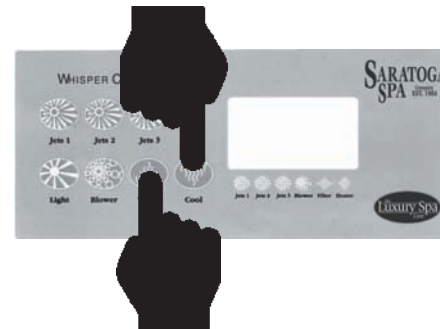

OPERATING THE HYDRO JETS:

Press the Jets 1, Jets 2 or Jets 3 pad to activate and deactivate the hydro jet pumps. Touch button once for low speed, again for high speed, and again to turn pump off. Either pump when activated, will automatically turn off after 15 minutes of operation. The spa light will begin flashing 15 seconds before the pump shuts off as a reminder.

Note: Jet 3 is high speed only then off.

Note: Jets 1 low speed will shut off after 4 hours of operation.

OPERATING THE AIR BLOWER:

Press the blower pad to activate the 3 stage blower. Touch the button once for high speed, again for medium and again for low. Press again to deactivate the blower will automatically turn off after 15 minutes of operation.

OPERATING THE MOOD LIGHT:

The mood light is activated by touching the button, once for highest intensity, again for lowest setting and a third time for OFF. The mood light will automatically shut off after 4 hours of operation.

Note: For on/off light operation, contact your Saratoga Spa Dealer.

SETTING THE TEMPERATURE:

The current temperature is constantly displayed on the control panel. When either pad is pressed, the set temperature will appear. Each time either pad is pressed again, the set temperature will increase or decrease depending on which pad is pressed. The warm button will increase desired temperature and the cool button will decrease desired temperature. The set point logo on the display tells if the display shows the current set point or the actual temperature of the water. The panel is preset at 1°F / -17°C. When the water temperature is 95°F / 35°C lower than the set point, the heater will come on until the water temperature reaches the set point. The heater logo on the topside will blink when the system calls for heat and will come on when heating.

Note: The above functions will not activate if panel or temperature lock is engaged. See page 7 for details.

NOTICE: Saratoga Spas are designed for maximum heat retention. The unit is not designed to cool water. If the set or desired temperature is below that of the ambient temperature, the unit will not be able to achieve this demand. Depending on the desired temperature, it may be necessary to add cool water to the unit to lower your spa's water temperature.

5. HYDROTHERAPY JET SYSTEM:

CLUSTER JET

- Small orifice for precise pressure point areas
- Produces high pressure for deep muscle penetration

MICRO CYCLONE SWIRL S/F

- Small rotational massage
- Adjustable eyeball for directional or rotational use

MICRO CYCLONE SWIRL L/F

- Gives mid-sized rotational massage
- Gives a pulsating massage for all parts of the body

MICRO CYCLONE FLOW L/F

- Soft powerful flo for direct pressure areas
- Higher GPM's for mid-size muscle groups

TWIN ROTATIONAL

- Small intense rotation to broad powerful rotation on large muscle areas
- Multiple adjustments for varied rotation intensities

GATLING JET

- A diffused pulsating massage
- Soft penetration for extended use

JUMBO JET

- Rotates over broad areas of the body
- Allows for heavy lower back massages

TURBO JET

- Provides high GPM through large orifice
- Provides intense lower body massage and whirlpool stimulation

6. SPA FILTER CARTRIDGE INSTALLATION:

WARNING: USE ONLY AUTHORIZED SARATOGA SPA CARTRIDGES.

ALL MODELS: FILL SPA TO MINIMUM OF 2" OVER THE TOP OF FILTER CARTRIDGES.

Note: Before running circulation system, all models must be filled 2" above the highest jet.

TRIPLE CARTRIDGE SYSTEM



REMOVABLE WEIR GATE

TO REMOVE SKIMMER LID:
Lift directly up and release from holding clips.



Whisper Clean Cartridge is on right from inside view, left from outside view.

(2) POWER FILTRATION CARTRIDGES: These cartridges are located on the outside with fine threads (NPT).

WHISPER CLEAN CARTRIDGES: This cartridge is located in the center. Filling spa and installing optional purifier cell takes place here. (ACME Thread)

7. SPA CARE AND MAINTENANCE:

Your Saratoga Spa is manufactured from the highest quality, most durable materials available today. We recommend that a spa maintenance program be followed. The care you take will ultimately determine how long your spa or its individual components will last. This section will help you maintain your investment.

FILTER MAINTENANCE

As with any water filtering system, the filter cartridges may become clogged with particles, body oils or calcification, that will result in poor water quality. It is important to maintain a clean unobstructed filtering system.

FILTER CARTRIDGE REMOVAL AND INSTALLATION

1. Remove and carefully set the skimmer cover off to the side.
2. Remove any floating items from within the filter compartment.
- 2A. Turn system off or put into SSet mode.
3. Grasp the top of the filter cartridge and turn clockwise until it is free from the base retainer. Leave Screen Adapter in place.
4. To reinstall the filter cartridge, reverse the order in which it was removed. **DO NOT OVER TIGHTEN!!**
5. Turn system back on. Reset temperature setting.

NOTE: Do Not use spa without Saratoga Spa Filter Cartridges In Place.

NOTE: Spa cartridges are a disposable item and are not covered under warranty.



VALVE MAINTENANCE ^(A)

Should valve become difficult to operate:

1. Shut system down.
2. Remove valve cover.
3. Clean or remove debris from valve or diverter.
4. Reassemble and thread down valve cover.

WARNING: Use only authorized Saratoga Spa Cartridges. The use of other spa manufacturers cartridges will void your warranty. The Whisper Clean Cartridge is specially made for your spa and can only be found at a Saratoga Spa Dealership.

WARNING: The Whisper Clean Filter Cartridge and Power Filtration Cartridge must be installed in the correct location, as shown. Improper installation may result in damage to the circulation system and will void your warranty.

FILTER CARTRIDGE CLEANING

1. Shut system off at GFCI or put into summer set mode. Remove cartridge.
2. Place the cartridge on a clean surface, spray with a garden hose. It will be necessary to rotate the cartridges to insure all filter pleats have been cleaned.
3. Complete cleaning by spraying down throughout the center of the cartridge (inside out).
4. Allow cartridge to dry. Reinspect and reinstall.
5. A complete and more thorough cleaning can be achieved by soaking cartridges in filter cleaner. Follow directions on the label.

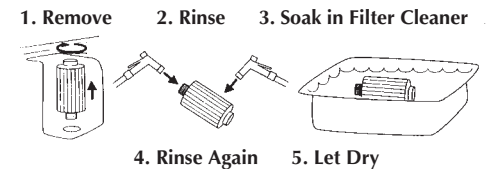

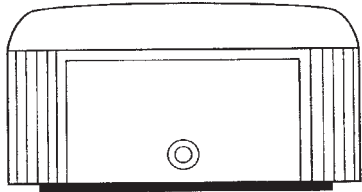
REPLACING LIGHT BULB

Replacement Bulb: GE 912 bulb.

Locate the light lens inside your spa. Remove the corresponding wood panel by unscrewing the six screws.

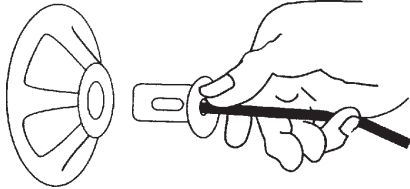

Grasp the bulb holder on the back of the light niche. Twist counter clockwise to release it from niche. Pull bulb out of receptacle. Replace and return to niche.

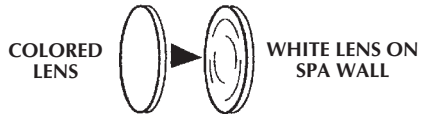

Colored lenses for your underwater mood light are optional with your spa. If desired, simply snap them over the light lens on the inside of your spa.

CARE OF THE EXTERIOR SURFACE (ACRYLIC SPA SHELL)

Your Saratoga Spa is manufactured with a tough Acrylic surface. Some staining or water marking may occur at or above the water surface.

Removal of these surface conditions can usually be accomplished with a soft cloth by merely wiping them away. Stubborn stains can be removed first by draining the spa and then using a nonabrasive product.

WOOD AND PLASTIC SPA SKIRT

The wooden or plastic skirt around your Saratoga Spa is manufactured with the finest quality materials available. A good quality wood sealer or natural color wood oil should be applied on the wooden skirt twice a year to keep your spa skirt looking good as new.

NOTE: DISCOLORATION OF THE WOODEN SPA SKIRT IS CONSIDERED NATURAL AND IS NOT COVERED BY THE SPA SURFACE WARRANTY.

Your Saratoga Spa dealer may stock original factory finish or recommend another sealer that is available in your area.

CARE OF THE THERMAL COVER

Your vinyl thermal spa cover has been designed for your particular spa. Monthly cleaning and conditioning is recommended to maintain its beauty.

To clean and condition the vinyl cover:

1. Remove the cover from the spa and lean it against a wall or fence.
2. With a garden hose spray away all loose dirt and debris.
3. Using a large sponge and a solution of two gallons of water to one teaspoon of dishwashing liquid, scrub the vinyl in a circular motion. Make sure to rinse all soap off the cover before it dries.
4. Be sure to rinse the inside of the cover without soap. Towel dry.
5. To condition the vinyl after cleaning, apply a thin film of saddle soap. (Follow directions on the container.)

Note: A complete line of cover care products are available. Contact your spa dealer for details.

IMPORTANT REMINDERS:

DO NOT WALK, SIT, OR STAND ON THE FOAM INSULATED COVER.

- **DO NOT DRAG OR LIFT THE SPA COVER USING THE FLAPS OR COVER TIE-DOWNS.**
- **ALWAYS REMOVE ANY SNOW BUILT UP TO AVOID BREAKAGE OF THE FOAM CORE.**
- **ALWAYS LOCK COVER STRAPS TO SECURE COVER TO THE SPA WHEN NOT IN USE.**

IMPORTANT: Whenever the spa is not in use it is essential that the thermal cover be kept in place. When filled this insures effective temperature maintenance and economical operation. When empty this prevents potential damage to the spas surface finish which can result from excessive heat caused by the sun. This type of damage is specifically excluded from warranty protection. It is recommended that the thermal cover tie-downs always be used to discourage access to the spa by unsupervised children and minimize heat loss.

WATER LEVEL

All models must maintain water level 2" above highest jet. Bather use and evaporation can lower water levels. Failure to maintain proper fill level will result in damage to the spa. Spas left uncovered are more prone to water loss resulting in the potential for severe water loss and damage to the unit and its surroundings not covered by warranty.

DRAINING THE WATER

TO DRAIN SPA:

1. Disconnect the spa from the power supply by tripping the GFCI breaker located in the house breaker panel.
2. Take off equipment access panel and locate hose bib shut off. Attach garden hose and route hose to an appropriate draining area.
3. Open the valve on the hose bib. The spa will drain by gravitational flow.
4. Saratoga Spas will drain to the lower suction fittings in the foot well of the spa. It may be necessary to vacuum or sponge up a small amount of remaining water in the spa.

DRAINING THE WATER (Continued)

5. When empty, inspect spa shell and clean as required.
6. Remove garden hose. Close valve - hand tighten.
7. Refill spa with tap water.
8. Reattach panel.
9. Restore power to spa.

WINTERIZING YOUR SPA

Follow directions 1 through 4 above (to drain spa).

5A. Hydro Jet Pumps:

1. Remove pump(s) from bracket(s) - Vacuum up water from return and suction sides of plumbing.
2. Reverse vacuum and blow out each line.

3. Remove drain plugs - Vacuum up water.
4. Put three cups antifreeze in wet end of pump(s).
5. Reinstall pump(s) with unions loose, drain plug out.

5B. 24 Hour Circulation Pump:

1. Disconnect 3/4 clamps from return and suction side of pump.
2. Remove pump.
3. Vacuum up both suction and return side of pump.
4. Reverse vacuum and blow out each line.
5. Vacuum up water from circulation pump.
6. Re-Attach pump and 3/4 hose.
7. From Whisper Clean cartridge add two cups of anti-freeze.
6. Loosen all unions.
7. Place cover on spa. Lock in place.

Note: Spa must be covered when empty.

8. WATER QUALITY MAINTENANCE:**GENERAL INFORMATION**

As the owner of a spa, endless hours of entertainment, recreation, and relaxation await you. Caring for your spa will become a routine and pleasant part of your daily activities. You will be able to maintain your spa water and keep your spa equipment in excellent condition. To do so you first must balance your spa's water.

BALANCED WATER

Balanced water insures spa bathers' safety as well as protecting the spa heater and components from corrosion. Also, balanced water protects the spa surface from unsightly scale deposits which reduce the efficiency of the spa equipment. You can obtain balanced water by correctly adjusting a few chemical components in the water. Specifically, you will need to adjust the pH, total alkalinity and calcium hardness

pH

pH is measured on a scale that runs from 0-14. pH indicates whether water is neutral, acidic, or basic.

The drawing below shows a pH equal to 7.0 is neutral. A pH below this point is acidic and a pH above this point is basic.

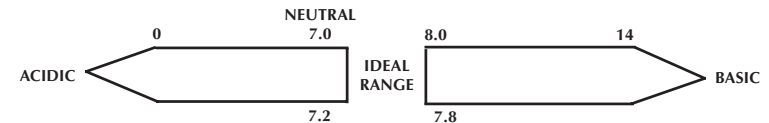

NOTE: Improper water chemistry can result in product failure and invalidate your warranty.
NOTE: Long term exposure and/or use of biguanide materials may void the Saratoga Spa warranty.

Example: At low total alkalinity levels, the water's pH easily drifts, making frequent pH adjustments necessary and more chemical treatment expense.

On the other hand, a high total alkalinity level keeps the water's pH rigidly fixed. If pH adjustment is necessary, you will need unusually large amounts of treatment chemicals to change the water's pH.

RECOMMENDED RANGE - 80 to 120 PARTS PER MILLION (PPM)

POTENTIAL PROBLEMS:

1. pH difficult to maintain. If total alkalinity is too low, pH will drift.
2. Corrosive tendencies. If total alkalinity is too high:
 1. pH difficult to adjust (it remains fixed.)
 2. Cloudy water.
 3. Potential for scaling.
 4. High pH and low sanitizer efficiency.

TESTING: WEEKLY

ADJUSTING TOTAL ALKALINITY

Total Alkalinity can be raised with Alkalinity Increaser at the manufacturer's recommendation for dosage.

CALCIUM HARDNESS

Calcium hardness is the amount of dissolved calcium in your spa's water. Too little calcium in the water will etch plaster surfaces, too much will leave deposits on surfaces and equipment.

RECOMMENDED RANGE: Above 200 ppm

POTENTIAL PROBLEMS

Calcium Hardness Too Low:

- Some surfaces may be etched.
- May lead to equipment corrosion.

Calcium Hardness Too High:

- May contribute to cloudy water.
- Scaling of surface, piping and equipment.

TESTING : WEEKLY

ADJUSTING CALCIUM HARDNESS

Raise hardness by the addition of calcium chloride. Decrease calcium hardness by draining spa and replacing with water containing lower levels of calcium hardness.

DISINFECTANT

Brominating Tablets, Granular Chlorine and a Non-Chlorine type shock are popular disinfectants and are particularly well suited to compliment your ozone purification system spa. They are also very suitable products in water with elevated temperatures.

Brominating Tablets are effective as a spa water sanitizer and disinfectant. Follow manufacturer's directions for proper dosage. It is recommended to maintain an active bromine residual of 2.0 to 4.0 ppm.

Granular Chlorine (Dichlor Dihydrate, Lithium Hypochlorite), is designed to dissolve quickly and completely, provide a steady source of available chlorine to control the growth of algae, kill bacteria and destroy organic contaminants. It is recommended to maintain a chlorine residual of between 1.0 and 3.0 ppm.

Non-Chlorine type shock will oxidize or destroy most of the organic contaminants that result from bather load. This quick acting oxidizing shock treatment goes to work almost immediately improving water quality and eliminating irritating wastes and odor. This product is intended to be a shock treatment only.

SHOCK TREATMENT

Adding disinfectant to the water in amounts much larger than normal is called shocking the spa. An occasional shock treatment destroys algae, bacteria, and chloramines. After shocking your spa, do not allow bathers to enter the spa until disinfectant levels drop to normal.

WHAT CAUSES LOSS OF DISINFECTANT?

- **ALGAE:** The presence of algae will consume large amounts of disinfectant. If you have an algae problem, the use of an algacide in addition to disinfectant may be necessary.
- **BATHER LOAD:** The greater the number of people using your spa, the more disinfectant you will need to use.
- **IMPROPER pH:** A high pH above 7.8 substantially retards disinfecting. Keep the pH between 7.2 and 7.8.
- **SUNLIGHT:** The sun's Ultraviolet (UV) rays readily dissipate disinfectant levels.
- **WATER TEMPERATURE:** High water temperature accelerates the loss of disinfectant.
- **WEATHER:** Rain and wind can carry a significant amount of contaminants into your spa.

REMEMBER:

pH 7.2 to 7.8
TOTAL ALKALINITY 80 TO 120 PPM
BROMINATING TABLETS AND NON-CHLORINE SHOCK 2.0 TO 4.0 PPM,
GRANULAR CHLORINE 1.0 TO 3.0 PPM
CALCIUM HARDNESS ABOVE 200 PPM

TEST pH WEEKLY

TEST DISINFECTANT DAILY

(Spa test kits are available through your Saratoga Spa Dealer.)

OZONE GENERATORS

Your Saratoga Spa comes equipped with an ozone generator. It automatically produces ozone 24 hours a day due to our Whisper Clean Continuous Circulation System.

WHAT IS OZONE?

Ozone is nature's natural purifier. It is a chemical known as O₃ and is produced from simple oxygen molecules in our atmosphere. Ozone will remove oils, greases, suntan lotions, sweat, urea, etc. from spa water more effectively than any other oxidizer commercially available. Ozone also assists chlorine, or bromine, to destroy bacteria and viruses and will do so more effectively. Ozone only leaves simple oxygen in the water as a by-product.

HOW IS OZONE PRODUCED?

Ozone is produced in nature from lightning during electrical storms and is also produced from ultraviolet rays from the sun to form our protective ozone layer. Your ozone converter uses a special corona discharge unit which duplicates this natural sanitizer.

Note: Always follow instructions and dosages listed by chemical manufacturers. Use only spa chemicals in your spa. Do not mix chemicals or add chemicals during bather use.

9. TROUBLE SHOOTING:

The following corrective actions can be undertaken by the spa owner. If the spa problem cannot be corrected after following these instructions, call your Saratoga Spa dealer for service.

SPA DOES NOT OPERATE:

1. Check main power to spa.
2. Check GFCI.
3. Check water temperature. If temperature is above 112°F., unit will automatically trip the internal high heat safety limit switch. The display panel will flash the temperature setting. In such a condition, turn off all power to the spa and contact your dealer or service center. **DO NOT ENTER THE WATER.**
4. If the display panel displays flashing "•••", check the following:
 - The filters may be plugged. Remove the filters and clean or replace.
 - The amount of water flow may be inadequate. Make sure water level is correct.
 - If the Bleeder System is not in use, the system may be air bound. Loosen clamp on 3/4 hose on top of the heater or circulation pump and relieve the air. Retighten clamp.

Note 1: If the open pressure switch error persists for more than five minutes, the circulation pump output will enter an open pressure switch error cycle which consists of stopping the circulation pump for 10 seconds, then start the circulation pump for 5 minutes. The cycle will repeat three times prior to a final power down of the circulation pump. If any manual key is pressed the system will restart three cycles.

- A flow switch may have malfunctioned. Contact your Saratoga dealer or service center. The spa will continue to operate, but the heater will not activate.
5. **Smart Winter Mode** - This system prevents the water from freezing in the plumbing of the pumps. An on-board sensor continuously checks the ambient air temperature in the control pack. If at any time the temperature falls from a range of 69°F to 55°F, the Smart Winter Mode will be activated for the next 24 hours, even if the temperature returns to above 69°F. During this Smart Winter Mode the range of temperature will determine the frequency of the pumps. The colder the ambient temperature, the more frequently the pumps will run. The time range will vary from every 15 minutes to every 2 hours. When the pumps are running because of this feature, the filter cycle icon on the display will flash. No corrective action is necessary.
 6. If the display panel is alternately flashing "SSEt" and the temperature, than your spa is in the summer setting mode. Your spa is equipped with Summer Setting to prevent heat buildup.

Standard Mode: When the water temperature is 2°F over the set point, the system will stop and water activation for 3 hours. After that period the circulation pump and the ozonator will turn on for a one hour period. This one hour activation of the circulation pump is followed by a one hour activation of pump one, low speed.

Indoor Mode: When the water temperature is 2°F over the set point, the system will stop and water activation for 3 hours. After that period, the circulation pump and the ozonator will turn on for a one hour period.

The circulation pump and ozone generator turns on automatically if the water temperature drops below 1° of the set temperature. No corrective action is necessary.

SPA SHUTS DOWN DURING NORMAL OPERATIONS:

1. Check venting around equipment area.
2. Check house GFCI breaker.
3. Check for water in control area.

PUMP DOES NOT WORK OR SURGES:

1. Check water level. Fill if necessary.
2. Check to see if filter cartridges are dirty. If so, then clean.

WEAK WATER FLOW:

1. Check and clean filter cartridges.
2. Jet inserts are not completely in jet.
3. Check volume control on jet insert.

WATER FLOW, BUT NO HEAT:

Remember, upon filling spa, do not expect instant hot water. It may take 12-24 hours to heat cool tap water to desired temperature depending on heater size.

1. Check cover on spa. Be sure it is in place.
2. Check water level. Fill if necessary.

WATER DOES NOT CLEAR UP:

1. Check water chemistry. Balance water.
2. Clean filter cartridges.
3. Check bromine or chlorine level. Shock if necessary.
4. Check ozone converter for proper operation.

NOTE: Spa water may be chemically saturated. If so, remove existing water and refill with new water.

CONTROL PANEL DOES NOT OPERATE

Check Panel lock feature:

To lock/unlock the panel, simply press on the blower key for at least 5 seconds. At that point, "Loc P" will display. If the key is released at this time, the keypad will partially lock (locks only the programming functions). However, if the blower key is kept pressed for another 5 seconds, "Lock F" will appear and the keypad will be fully locked (locking all keypad functions).